

MAX-TENSION™ TL-2

The MAX-Tension™ TL-2 tangent guardrail terminal, with Sabertooth™ technology, features the next level of impact performance and an ultra-slim design. The system utilises a tension-based design along with an energy absorbing coupler that features an all new cutting tooth design. When impacted head-on, deceleration is controlled by friction developed in the tension cables and by cutting the downstream guardrail panels. When a side impact occurs, tension cables can help safely redirect a motorist away from the hazard.

In addition, the MAX-Tension terminal utilises standard guardrail components and shares many “smart parts” with other MAX-Tension Terminal designs for significant savings in inventory and maintenance costs. Nuisance impacts during snow removal and maintenance operations can also be minimized due to the narrow design of the MAX-Tension impact head.

Features

- > Redirective, non-gating at post 1
- > Tension-based cables control deceleration and increase re-directive performance.
- > Sabertooth technology increases energy absorbing capacity and weakens the downstream guardrail rail to help reduce the severity of impacts.
- > Lightweight impact head makes installation quick and easy.
- > Available as a kit or full system, utilizes standard guardrail panels, posts and components after post 1.

Where to use

Side of road where a recommended clear zone and recoverable slope is attainable.

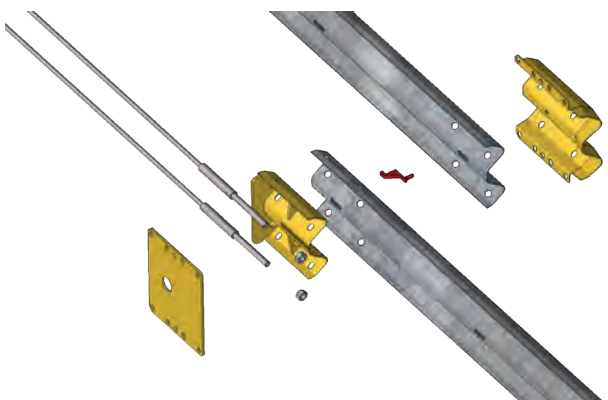

The MAX-Tension Energy Absorbing Coupler (gold) is fitted with a patent pending galvanized Sabertooth (red). When the system is impacted head-on, the Sabertooth is engineered to cut the downstream guardrail to aid in the deceleration of an errant vehicle.



PHYSICAL SPECIFICATIONS

Classification	TL-2 Redirective, Non-Gating	
System Length	15'	472 cm
Effective Length	25'	762 cm
System Width	17.5"	445 mm
Impact Head Width	5.5"	140 mm
Impact Head Weight	40 lb	18.14 kg
Beginning Length of Need	Post 1	Post 1

